



BrikStar C
Hydraulic briquette
machine

HÖCKER®
POLYTECHNIK

Always one idea ahead



BrikStar C

C like „compact“.

All types of this series are delivered compact and ready for plug-in as a complete press with frame mode construction and integrated hydraulic - for an extremely competitive cost-benefit-ratio. BrikStar C3 is perfectly made for crafts enterprises or industries with low quantities of pressed material, for higher throughput C4, C5, C7 and C11 are available. The briquette diameter of 65mm is ideal for transport and storage.

All inclusive.

Hour counter, oil level monitor, paddle switch (auto start and stop), oil-cooler (standard only for C7 and C11), inspection door with interlock guard switch as well as a display that continuously shows clamping pressure and temperature, are standard

Compacted technique.

The paddle switch controls the automatic start and stop and saves unnecessary operation hours. Furthermore the standard inspection door with interlock guard switch guarantees operation without risk. A rugged screw feeder loads the press chamber. The feeding chute is generously sized to enable high throughput even when coarse and lightweight material is being compressed. All presses can be loaded manually or automatically without problem.

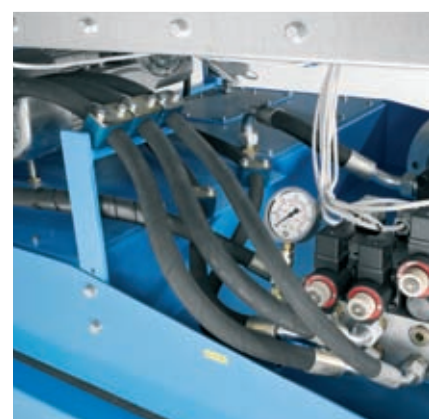
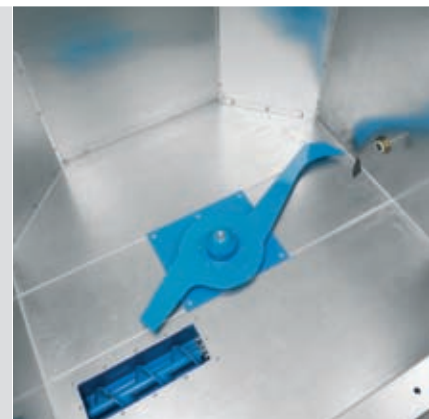



ADVANTAGES / BENEFIT:

- solidly built connecting flange for transport chute → dimensioned for long distances as well
- briquette diameter 65mm → ideal for transport and storage
- very solidly constructed hydraulic press clamp and electronically controlled briquette length → minimises operation costs and assures high quality briquettes
- generously dimensioned main briquetting cylinder → outstanding briquette quality even when the material is less compressible
- low noise hydraulic with vibration damper → absorbs operation sound
- real PLC (programmable logic controller) → flexible technique, quick start up
- high quality-built → long durability and low follow-up costs
- optimised hydraulic and auto start and stop → low energy consumption in relation to output

TIPS FOR PLANNING.

- An outside installed hydraulic briquette machine has to be protected from rain. (see chargeable options → protective housing)
- For continuous operation without any breaks a separate oil cooler is required (chargeable option, standard for BrikStar C7 and C11). Furthermore an oil heater to ensure the reliable start-up during extremely cold temperatures may be necessary (chargeable option).
- Clearances of 60cm on the operator side and 100cm on the discharge side are required for maintenance access.

Technical Data

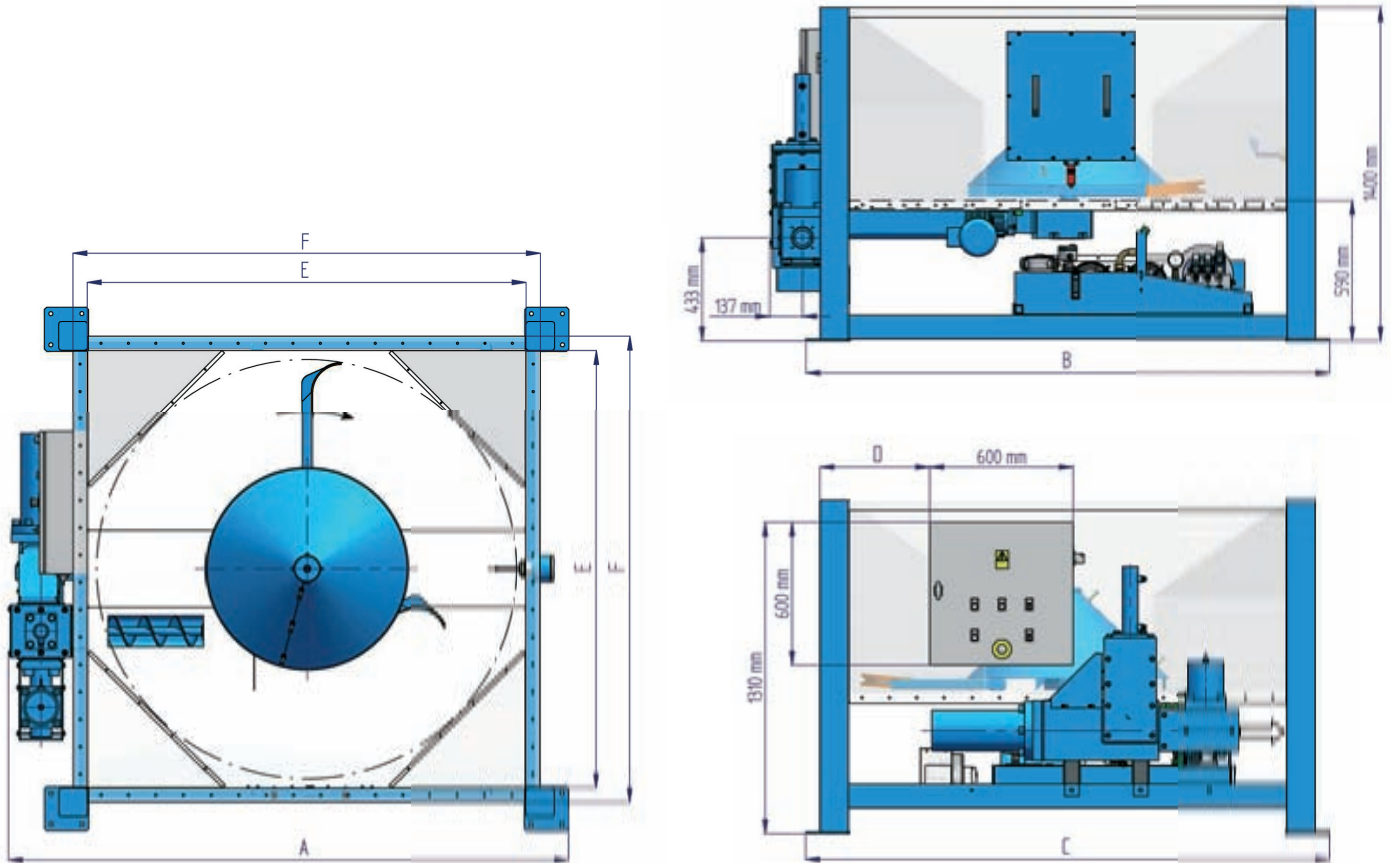

Type	Output (material dependent)	Motor hydraulic* (kW)	Motor screw* (kW)	Weight (kg)** -14 / -18 / -23	Capacity of hopper (gross)
BrikStar C3	25 bis 50 kg/h	3.00 kW	0,75	950/1040/1240	
BrikStar C4	35 bis 70 kg/h	4.00 kW	0,75	960/1050/1250	C...-14: ca. 1,3 m ³
BrikStar C5	45 bis 90 kg/h	5.50 kW	0,75	1030/1100/1320	C...-18: ca. 2 m ³
BrikStar C7	55 bis 110 kg/h	7.50 kW	1,1	1330/1420/1630	C...-23: ca. 3,2 m ³
BrikStar C11	75 bis 150 kg/h	11.00 kW	1,1	1400/1490/1700	

• Briquette diameter: 65mm • No guarantee is given for the correctness of these details; subjects to technical changes and misprints.

* Electrical motors require 3~, 400V, 50Hz. Other voltages or frequencies on demand (chargeable option).

** depends on capacity of hopper

Type	A (mm)	B (mm)	C (mm)	D (mm)	E (mm)	F (mm)	Motor agitator* (kW)
BrikStar Cx-14	1850	1630	1630	110	1380	1500	0,37
BrikStar Cx-18	2350	2200	2200	460	1840	1960	0,37
BrikStar Cx-23	2810	2660	2660	690	2300	2420	1,1

CHARGEABLE OPTION:

- additional paddle switch; e.g. as hopper "full" level indicator
- left-hand version, briquettes move from right to left (note: larger footprint and extended delivery time)
- hydraulic oil heater, for an outside installed machine
- separate oil cooler for continuous operation (standard in C7 and C11)
- protective housing for outdoor installation
- discharge chute with spring retainer
- further options on request

HÖCKER POLYTECHNIK GmbH

Borgloher Straße 1 · 49176 Hilter · Germany · Fon + 49 (0)5409 405-0 · Fax + 49 (0)5409 405-555

www.hoecker-polytechnik.de · info@hpt.net

HÖCKER
POLYTECHNIK
Always one idea ahead