



BrikStar CS/C-12
Hydraulic Briquette machine



HÖCKER[®]
POLYTECHNIK

Always one idea ahead



BrikStar CS/C-12

BrikStar CS/C-12

Hydraulic
Briquette machine

Concentration on the substantial

Our small and compact range of BrikStar C-12 and BrikStar CS-12 is perfectly made for crafts enterprises or industries with low quantities of pressed material. All types of this series are delivered compact and ready to use (plug-in) as a complete press with frame mode construction and integrated hydraulic – for an extremely competitive cost-benefit ratio.

Slender technique

The agitator and screw feeder are solidly built; each is driven by its own gear motor to ensure maximum reliability. The control is effected by a modern PLC (programmable logic controller) combined with an automatic switchoff to reduce unnecessary hours of operation. The length and throughput of the briquettes varies according to the feed material, the density of the briquettes remains constant.

Varying accessories

For an outdoor use of the briquetting press we deliver protective housings and – for extremely cold temperatures – an oil heater. For continuous operation without any pauses the BrikStar C-12 can as well be equipped with separate oil cooler.

Due to their compact design the whole range of BrikStar CS can easily be refitted under almost any filter installation as they were especially constructed to be installed under a deduster or filter installation according to DIN EN 12779.





BrikStar C with protective housing, installed under a Höcker Polytechnik filter installation.

HÖCKER®
POLYTECHNIK

Concentrated advantages

- complete plug-in briquetting press including hydraulic aggregate -> reduces installation costs
- real PLC (programmable logic controller) -> flexible technique, quick start up
- briquette diameter = \varnothing 65mm -> ideal for transport and storage
- solidly built connecting flange for transport chute -> dimensioned for long distances as well
- hopper with motorised agitator and a screw feeder that pre-compresses the material, with deflector plates in the corners -> the hopper is emptied reliably and bridging is prevented
- main briquetting cylinder generously dimensioned -> outstanding briquette quality even for those materials difficult to briquette
- low noise hydraulic with vibration damper -> absorbs operation sound
- extremely solid hydraulic clamping sleeve -> constant quality of briquettes even with varying material

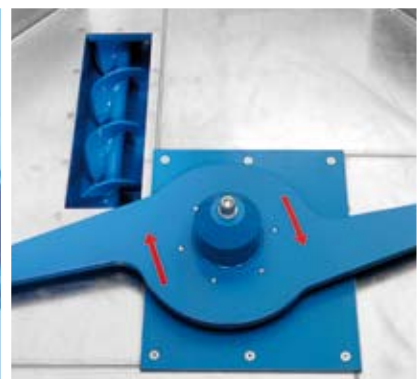
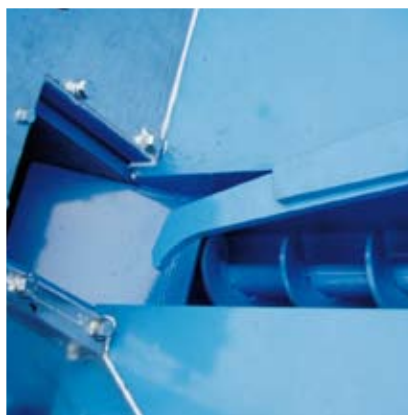

Technical Data

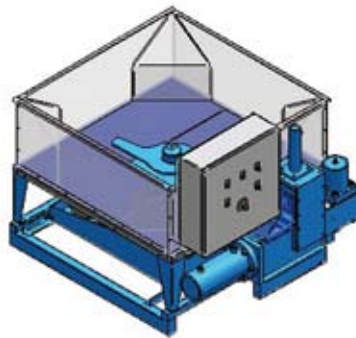
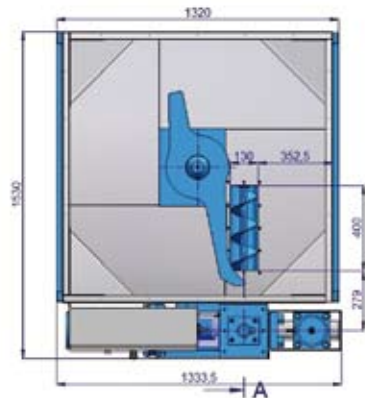
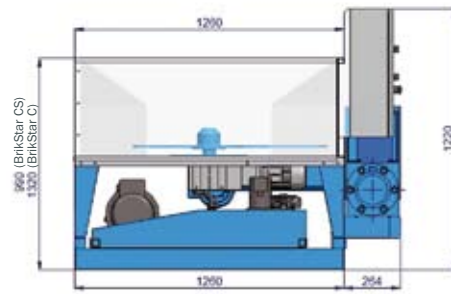
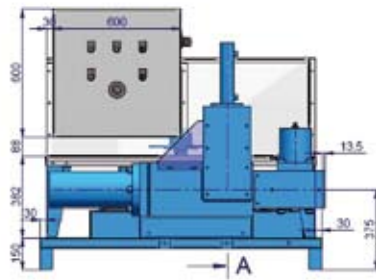

Dimensions apply to right-hand version only
Footprint of left-hand version: 1.670 x 1.530 mm

Type	Output (material dependant)	Motor* hydraulic	Motor ** agitator screw	Weight	Height of hopper	Capacity of hopper
BrikStar CS3-12	20 – 40 kg/h	3 kW	0,37/ 0,75 kW	approx. 770 kg	990 cm	approx. 0,8 m ³
BrikStar CS4-12	30 – 60 kg/h	4 kW	0,37/ 0,75 kW	approx. 780 kg	990 cm	approx. 0,8 m ³
BrikStar C3-12	25 – 50 kg/h	3 kW	0,37/ 0,75 kW	approx. 780 kg	1300 cm	approx. 1 m ³
BrikStar C4-12	35 – 70 kg/h	4 kW	0,37/ 0,75 kW	approx. 790 kg	1300 cm	approx. 1 m ³
Briquette diameter: 65 mm						
* Note: continuous operation requires a separate oil cooler (option)						
** Electrical motors require 3~, 400V, 50Hz; other frequencies or voltages are chargeable options						

Chargeable options:

	CS-12	C-12
Inspection door (optional with interlock guard switch, a tool is required for opening the door, in compliance with safety regulations)	*	standard
Paddle switch, initiates automatically press cycle or signals hopper level "full" and / or "empty"	*	standard
Left-hand version, briquettes move from right to left (note: larger footprint and extended delivery time)	-	*
Heater for hydraulic oil, for an outdoor installation of briquetting press	*	*
Separate oil cooler, for continuous operation	*	*
Discharge chute with adjustable spring retainer	-	on request
Adaptor ring for hopper	-	*
Filling level detector (full indicator)	*	*

* = chargeable option - = not available

No guarantee is given for the correctness of these details; specifications can be subject to change w /o notification.

HÖCKER POLYTECHNIK GmbH

Borgloher Straße 1 · 49176 Hilter · Germany · Fon + 49 (0) 5409 405-0 · Fax + 49 (0) 5409 405-555

www.hoecker-polytechnik.de · info@hpt.net

HÖCKER®
POLYTECHNIK
Always one idea ahead